

CT-11 SOUNDER INSTALLATION MANUAL

Both of the CARTELL control units can operate up to twelve annunciator plates.

The annunciator plate mounts on a single-gang electrical box, or can mount directly on the wall. Mount all plates flush in the wall.

All connections are made to a screw terminal on the back of the annunciator plate circuit board. Use CAT-5 wire. Solder-tin the ends of the wires before connecting to the control unit to avoid corrosion.

After you have run cable from the control unit to the annunciator(s), always connect the wire to the annunciator first and then to the control unit.

NOTE: After connecting wires to the annunciator and before connecting to the control unit, measure the resistance between the wire you choose for the positive connection and the wire you choose for the negative connection. The resistance should never be less than 75 ohms total. Resistance less than 75 ohms shows damage to the wire between the control unit and annunciator (e.g., a staple through the wire) and will damage the power supply.

CONNECTING CT-11 TO CT-2B

At the annunciator:

- Connect the positive lead to the terminal marked “+”.
- Connect the negative lead to the terminal marked “-”.

To connect CT-11 to the CT-2B:

- At the control unit, test the resistance positive to negative as noted above before proceeding, then:
- Connect the “+” lead to terminal No. 9.
- Connect the “-” lead to terminal No. 8.

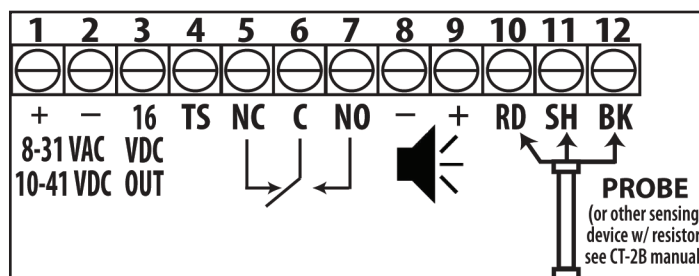

CONNECTING CT-11 TO CF-2C

At the annunciator:

- Connect the positive lead to the terminal marked “+”.
- Connect the negative lead to the terminal marked “-”.

To connect CT-11 to the CF-2C:

- At the control unit, test the resistance positive to negative as noted above before proceeding, then:
- Connect the “+” lead to terminal No. 14.
- Connect the “-” lead to terminal No. 15.

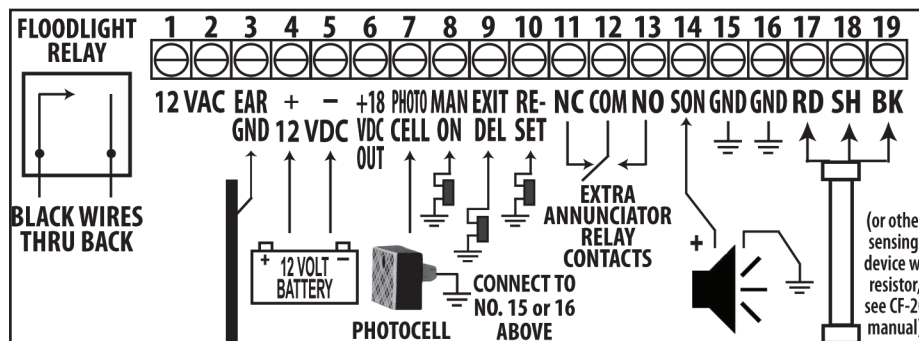

In the unlikely event of product or installation problems, call 717-532-0033 (option 1) for help.

510 West King Steet, Shippensburg, PA 17257 ♦ 717-532-0033 ♦ cartell.com

