

# CT-A1 SOUNDER INSTALLATION/OPERATION

## OPERATIONAL FEATURES

### THREE TONES:

The CT-A1 allows three tones: steady, slow-pulse, fast-pulse. It is suggested the installer sample the tones for the customer to choose. To hear a sample of the steady tone, push the button marked "PROG." To hear a sample of the slow-pulse tone, push the button marked "DOWN." To hear a sample of the fast-pulse, push the button marked "UP." NOTE: power must first be applied to the CT-A1 before it will sound.

### PROGRAMMING VOLUME

- To adjust volume, keep the button marked "PROG" pushed in the entire time you are increasing or decreasing volume (it will continue to sound as long as it is pushed in, demonstrating adjusted volume).
- With "PROG" pushed in, push the button marked "UP" to increase volume one increment. Keep
- "PROG" pushed in, wait one second, and push "UP" again. Repeat until desired volume is reached.
- With "PROG" pushed in, push the button marked "DOWN" to decrease volume one increment. Keep
- "PROG" pushed in, wait one second, and push "DOWN" again. Repeat until desired volume is reached.

NOTE: when highest or lowest volume setting is reached, the LED will blink once.

### MUTING SOUNDER

To mute sounder, keep "PROG" button pushed in and push the "DOWN" button two times in quick succession (in less than one second). The LED will begin blinking and continue blinking the duration of the mute cycle. To restore sound, hold "PROG" button down and push the "DOWN" button two times in quick succession as before. The LED will stop blinking when sound is restored to its previous setting.

### ADJUST TIMING (OPTIONAL)

The default timing for the CT-A1 is set at the control unit (see "Adjusting Sounder Time" in manuals). However, if a longer sounding time is desired for individual CT-A1's, it can be lengthened by turning the pot on the sounder's circuit board counter-clockwise (CCW).

"ON", "RESET" AND "EXIT" ADDITIONAL FEATURES AND "CHIRP" (WHEN USED WITH CF-2C)

The "ON" button instantly turns on the floodlights for the time period set by the control unit. "RESET" instantly cancels the floodlight timer and turns off the lights operated by the CF-2C.

"EXIT" button activates the preset exit delay timer, de-activating the sensor probe. This allows a vehicle to drive by the probe without tripping the system.

These buttons lack a tactical feel, but when pushed, a small audible "CHIRP" should be heard.

## INSTALLATION INSTRUCTIONS

### MOUNTING

Install the CT-A1 in a single-gang electric box for flush mounting.

### WIRE

Use CAT-5 wire. To avoid corrosion, solder-tin the ends of the wires before connecting to the sounder and control unit. Always connect the wire to the sounder first and then to the control unit.

### WIRE CHECK-OUT

After connecting wires to the sounder, and before connecting to the control unit, systematically measure the resistance between each wire with every other wire. Resistance should never be less than 75 ohms. Resistance less than 75 ohms shows damage to the wire between control unit and sounder (e.g., a staple through the wire) and will damage the power supply if it is connected to the control unit.

### REQUIRED WIRES

Three wires are required when used with the CT-2B (See Figure 1 next page).

Six wires are required when used with CF-2C (see Figure 2 next page).

If replacing an FC-9 and only five wires have been previously installed, it is recommended the reset function be dropped, as it is automatic.

Multiple control units sharing one CT-A1 requires all eight wires. Only one control unit needs to provide the power. However, the CT-A1 must be grounded to all control units (see Figure 3 next page).

## CONNECTING CT-A1 TO CT-2B

See Figure 1.

Connect wires to CT-A1 first, then to the CT-2B, making sure to match wire colors.

- At CT-A1, connect a wire to terminal "V." At CT-2B, test resistance and connect to term. 3.
- At CT-A1, connect a wire to terminal "G." At CT-2B, test resistance and connect to term. 8.
- At CT-A1, connect a wire to terminal "S" (for steady tone) or "P1" (for fast pulsating tone) or "P2" (for slow pulsating tone). At CT-2B, test resistance and connect this wire to terminal 9.

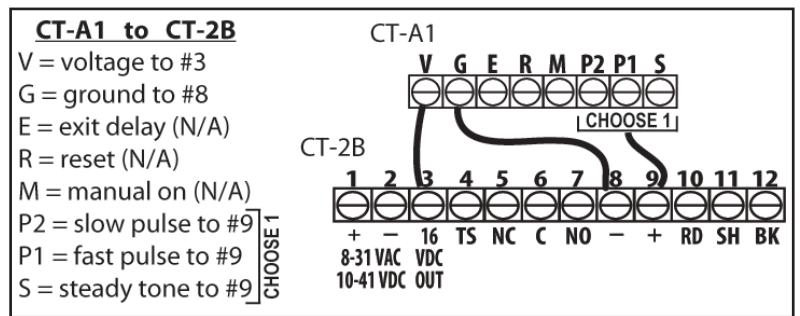

Figure 1

NOTE: The three extra functional buttons on the CT-A1 ("ON", "RESET", "EXIT") are non-functional when used with the CT-2B. They should be ignored.

## CONNECTING CT-A1 TO CF-2C

See Figure 2.

Connect wires to CT-A1 first, then to the CF-2C, matching wire colors.

At CT-A1, connect a wire to terminal "V." At CF-2C, test resistance and:

- Connect this wire to terminal 6.
- At CT-A1, connect another wire to terminal "G." At CF-2C, test resistance and connect this wire to terminal 15.
- At CT-A1, connect a wire to terminal "S" (for steady tone) or "P1" (for fast pulsating tone) or "P2" (for slow pulsating tone). At CF-2C, test resistance and connect this wire to terminal 14.
- At CT-A1, connect a wire to terminal "E." At CF-2C, test resistance and connect this wire to terminal 9.
- At CT-A1, connect a wire to terminal "R." At CF-2C, test resistance and connect this wire to terminal 10.
- At CT-A1, connect a wire to terminal "M." At CF-2C, test resistance and connect this wire to terminal 8.

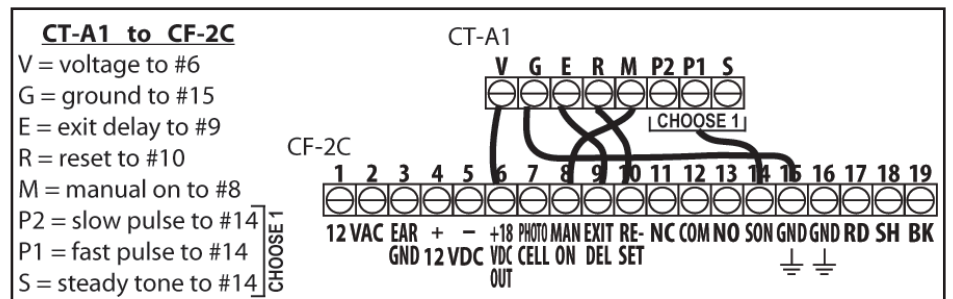

Figure 2

## CONNECTING CT-A1 TO A THREE-DRIVEWAY SYSTEM

See Figure 3.

For a two or three-driveway system, each driveway must have a completely separate system (control unit and sensor probe for each driveway). By hooking three systems to one CT-A1 and utilizing its three tones, each driveway may be differentiated by its own tone.

Connect wires to CT-A1 first, then to the control units.

Remember to test resistance as noted above before connecting to control units.

Follow all instructions above for connecting to CF-2C.

- Utilize first CT-2B by connecting terminal "G" at CT-A1 to terminal 8 on the first CT-2B; and terminal "P1" at CT-A1 to terminal 9 on the first CT-2B.
- Utilize second CT-2B by connecting terminal "G" at CT-A1 to terminal 8 on the second CT-2B; and terminal "P2" at CT-A1 to terminal 9 on the second CT-2B.

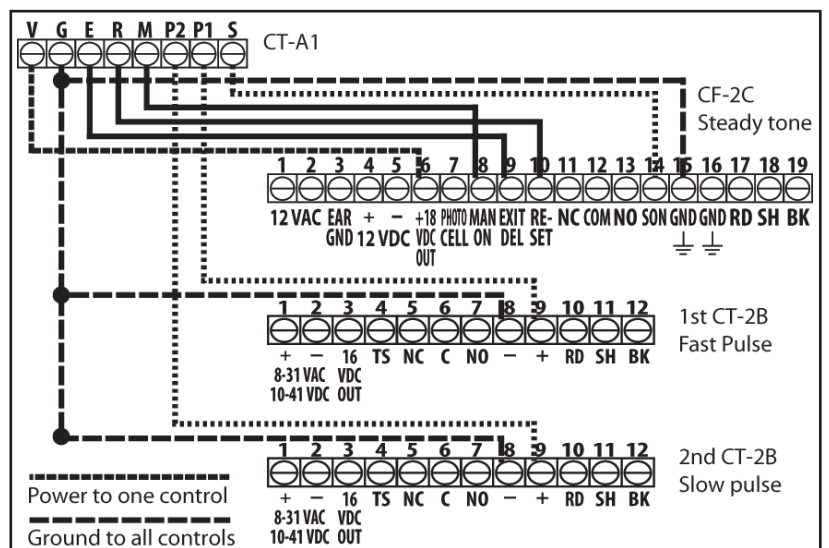

Figure 3



In the unlikely event of product or installation problems, call 717-532-0033 (option 1) for help.

